

CAD FILE :

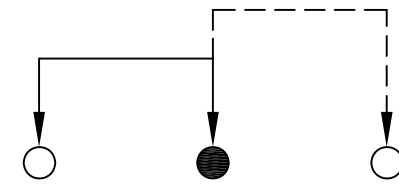

**SCHMATIC (SHORTING)**

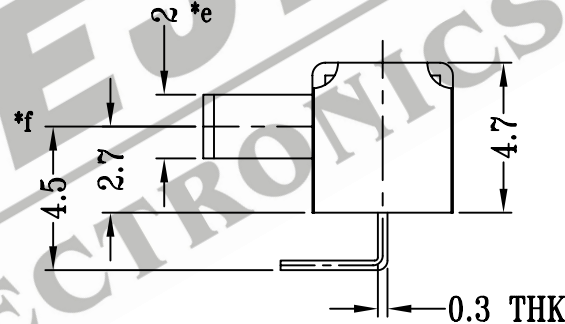
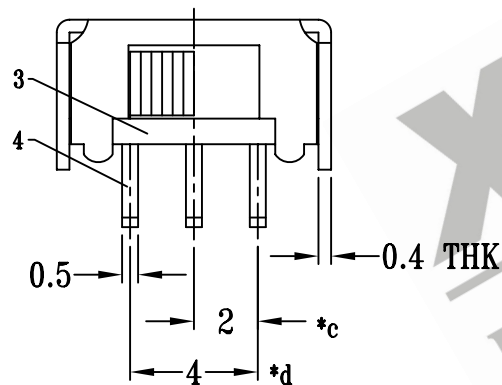
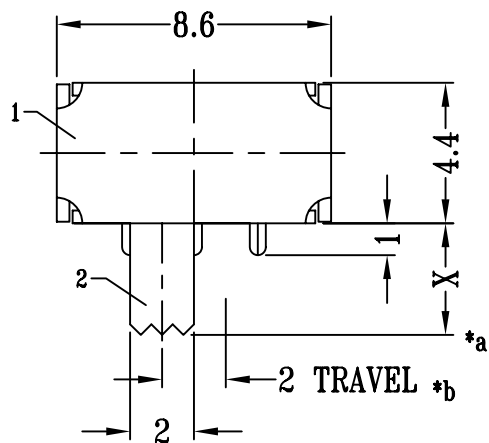
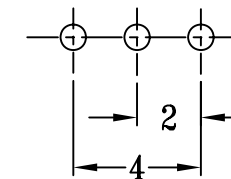

**P.C.B LAYOUT**

注:带"\*"表示关键尺寸(6个)

NO.	PARTS	MATERIALS	Q'TY	FINISH	TOLERANCE UNLESS SPECIFIED	SHENZHEN XIEJIA ELECTRONICS CO.,LTD.				
8					WITHIN: 1.5±0.1mm OVER: 1.5±0.2mm	ISSUE	DATE	DESCRIPTIONS OF REVISION		APPD
7						TITLE: HORIZONTAL SLIDE SWITCH		UNIT : mm	DRWG NO : XJ-DR-SK12D11-00	
6	SPRING PLATE	STAINLESS STEEL	1	NATURAL	MODEL: SK-12D11	SCALE : 4 : 1		DWN.	ZHOUYU	2003-9-12
5	CONTACT CLIP	PBS	1	Ag CLAD		CHK'D	FANGYING	2003-9-12		
4	TERMINAL	BRASS STRIP	3	Ag PLATED OVER Ni PLATED	ALL MATERIALS MUST BE COMPLIANT TO ROHS		APPD.	KANGXINAN	2003-9-12	
3	BASE	PHENOLIC RESIN	1	NATURAL						
2	KNOB	POM	1	BLACK						
1	FRAME	STEEL STRIP	1	Ni PLATED						